

Meter Installation

– *and* –

Padmount Transformer Guide

April 2007

Nodak
ELECTRIC COOPERATIVE

Your Touchstone Energy® Partner 

METERING REQUIREMENTS

The following information shall be used as a guide for installing metering equipment. A self-contained meter has all load current passing through the meter. CT metering refers to load currents passing through current transformers. If there are any questions or if a change is desired, please contact the Engineering Department or Energy Services at 746-4461 or 800-732-4373.

Self-contained Metering (Main Service)

Note: Three-phase, 320-amp meter sockets are not approved. The metering of 480-volt self-contained services shall be minimized by using Potential Transformers (P.T.) to reduce the voltage seen at the meter to improve reliability and safety.

Meter located on pole or pedestal

Nodak shall:

- ✓ Provide a meter socket with lugs, lever bypass and the meter.
- ✓ Provide, install and connect the secondary conductor between meter socket and transformer.

If customer wants Nodak to provide a knife-blade double throw disconnect, he shall:

New accounts or expansion of existing accounts

- Reimburse Nodak the cost difference between a meter socket and knife-blade double throw disconnect.

Existing accounts (adequate service)

- Reimburse Nodak the cost of the knife-blade double throw disconnect and pay all labor costs.

(Nodak will retain ownership and maintain disconnect.)

Meter mounted on customer's building

Nodak shall:

- ✓ Provide the meter, install and connect the secondary conductor between meter socket and transformer.

Customer shall:

- ✓ Provide a meter socket with lever bypass to meet Nodak's specifications.
- If customer wants Nodak to provide a knife-blade double throw disconnect, he shall:
- Reimburse Nodak the cost of the disconnect.
 - Have electrician install disconnect. (Nodak will retain ownership and maintain disconnect.)

Transformer Rated Metering (Main Service)

Nodak shall:

- ✓ Provide the current transformers (CTs) and meter socket.
- ✓ Provide the meter.
- ✓ Provide the secondary connectors at the transformer.
- ✓ Install metering circuit conductors from CT to meter socket.

Customer shall:

- ✓ Connect the customer's secondary conductor to the transformer. (Nodak will assist with overhead transformer connections.)
- ✓ Arrange for picking up all metering equipment at Nodak's warehouse in Grand Forks.
- ✓ Provide and install the CT cabinet and secondary conductors from the transformer (or transition cabinet) to the service panel.
- ✓ Install a one-inch conduit between CT cabinet and the meter socket (maximum distance of 25 conduit feet with total conduit bends not to exceed 270° from CT to meter socket).
- ✓ Provide and install the secondary connectors at the current transformers.

Note: CT cabinet must be minimum size of 24" X 36", contain landing pads and accommodate Nodak's padlock. Meter socket may not be mounted on CT cabinet door.

Off-peak (All GS Accounts) (Submetered only)

Nodak shall:

- ✓ Provide the meter and one load management receiver.

Customer shall:

- ✓ Provide a meter socket with lever bypass for direct sub-metered off-peak loads, or
- ✓ Provide a meter socket with shunt bypass and current transformers.

INSTALLATION GUIDELINES

- All meters must be accessible to Nodak personnel. Main meters shall not be mounted on the back side of residences.
- Only one conductor per leg may be placed in a 200-amp meter socket or Nodak-owned disconnects.
- The meter shall be mounted at a height between four feet and six feet from final grade. A minimum clearance of three feet in front of the meter shall be maintained.
- CTs are not allowed inside a padmount transformer (nothing shall be installed in or mounted on the transformer). The CTs must be located in an area that can be sealed and padlocked by Nodak. Access to any CT cabinet or transition cabinet is prohibited without authorization by Nodak.
- Nodak's metering personnel will install the current transformer and potential transformer leads for direct metered installations (Figure 2) and install the meter. The contractor shall install wiring between the CTs and meter for submetered installations (Figure 1). The wiring connections will be made by Nodak.
- If multiple runs of secondary are installed, adequate tagging shall be installed on each run to assure proper installation and assist Nodak personnel in inspecting the final installation.
- No self-contained meter socket shall be bypassed. The only exception is submetered applications, which may be slugged with Nodak-supplied socket jumpers.
- If off-peak is installed, it is the responsibility of the customer or electrician to notify Nodak when completed, at which time Nodak will inspect and code the installation. Any usage at the account will be billed on the regular rate until coded, at which time the applicable Off-peak Rate will be applied.
- The installation must meet the current National Electric Safety Code, National Electric Code, and be certified by the ND State Electrical Board.

METERING SCHEMATICS

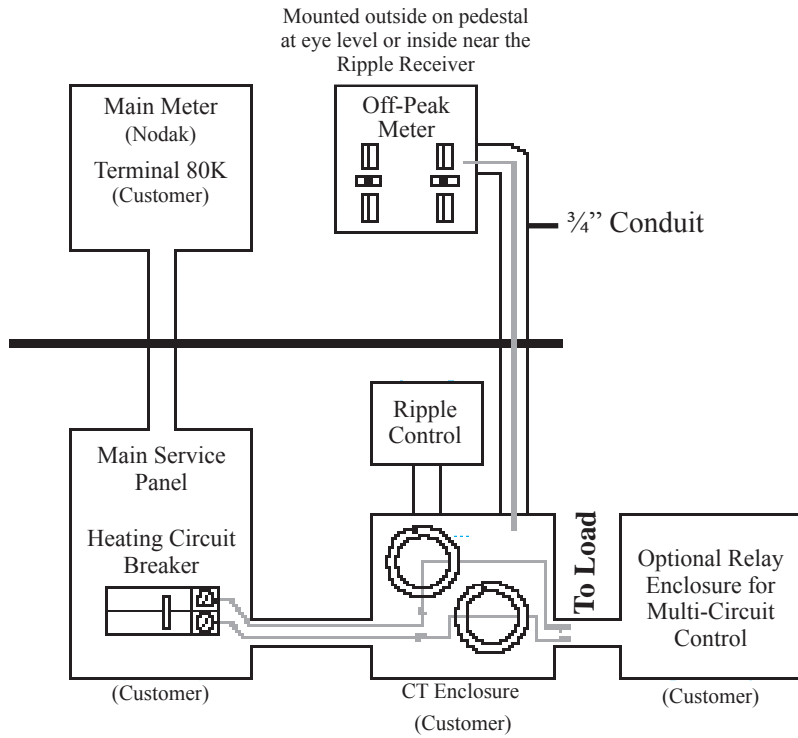

FIGURE 1
Off-peak/Submetered
Using Current Transformers (CT)

- ✓ Leave wire nuts on CTs. Connections in meter socket and CT Enclosure made by Nodak personnel.
- ✓ Install 7 #12 AWG wires: **color coded or labeled.**

2 - #12 - CT
 2 - #12 - CT
 2 - 240 Volt Supply
 1 - Ground

FIGURE 2
CT Metering

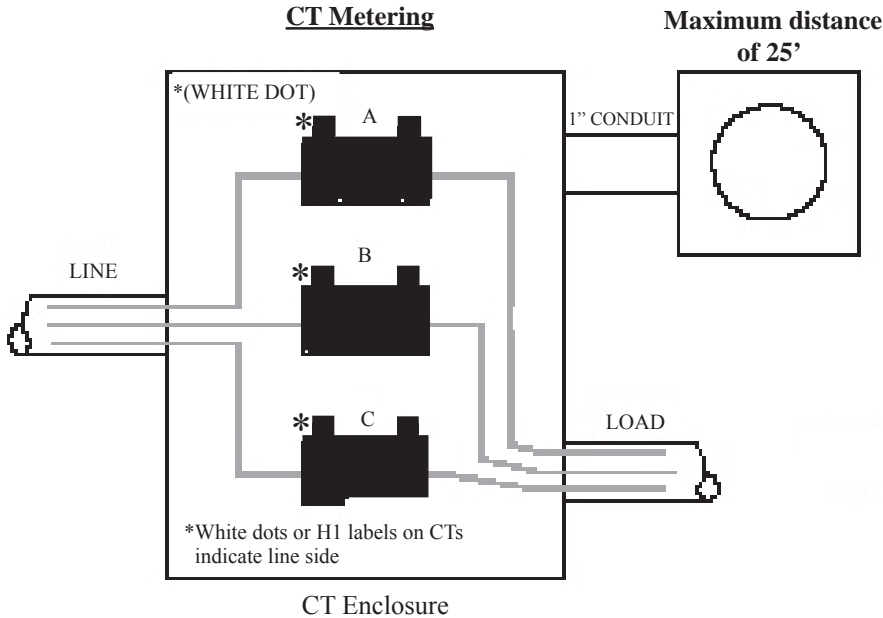
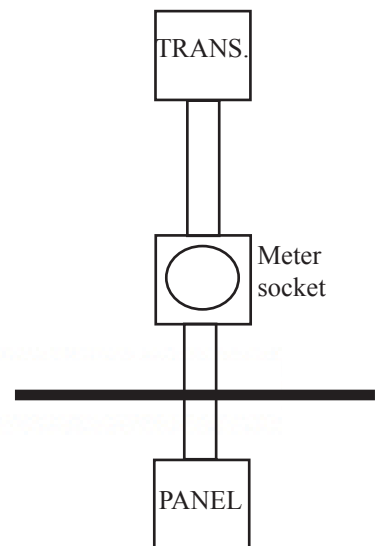

FIGURE 3
Self-contained Meter



PADMOUNT TRANSFORMER REQUIREMENTS

Nodak shall provide:

- ✓ Primary conductor, transformer, ground grid, and transformer pad (single phase only).
- ✓ Ground sleeve (basement) under pad.
- ✓ Secondary conductors for metered services that are self-contained, if requested.
- ✓ Secondary conductor connectors at the transformer.

Customer shall provide:

- ✓ Secondary conductors and conduit for metered services that are current transformer rated.
 - Transformer pad (three-phase).
 - Pad shall be to Nodak specifications.
 - Customer has option of paying Nodak to provide pad.
- ✓ The number and size of conduits and conductors run into the transformer are limited to the following:
 - Maximum of four (4) 4-inch conduits.
 - Maximum of four (4) conductors per phase.
 - Maximum conductor size of 500 MCM.
- ✓ Transformer guard posts, if transformer is exposed to traffic areas.
- ✓ 4" conduit shall be installed under any hard surfaced area for Nodak to install primary cable in.

Transition Cabinet Requirements

If the service entrance requires more than four conductors per phase, a secondary connection (transition) cabinet must be installed.

Nodak shall:

- ✓ Provide and install in the customer's conduit the secondary conductors and terminations between the transformer and transition cabinet.

Customer shall:

- ✓ Provide and install the transition cabinet and pad.
- ✓ Provide and install five (5) 4-inch conduits between the transformer and transition cabinet.
- ✓ Connect the customer's secondary to the load side of the transition cabinet.

Transition Cabinet Specifications

- ✓ Minimum distance from ground line to the lowest secondary termination shall be 24 inches.
- ✓ Cabinet shall be located adjacent to padmount transformer.
- ✓ If cabinet includes CT provisions, it must be able to be secured with a padlock.

CLEARANCE REQUIREMENTS FOR TRANSFORMER PAD

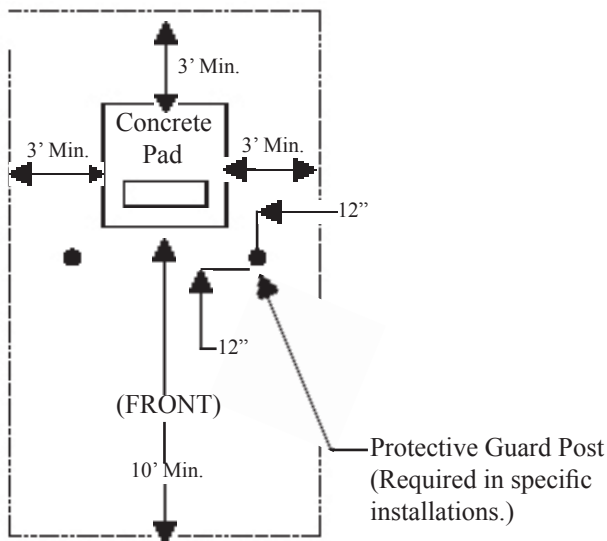

Padmount Transformer

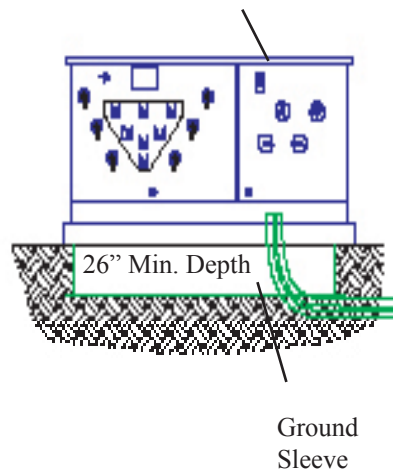

Transition Cabinet (Consumers – Required if more than 4 conductors per phase.)

